

Growing Crops for a Changing Climate: Insights from Cassava Field Experiments

Dr Temitope Odedeyi

Royal Academy of Engineering
Research Fellow

University College London

9 March 2026



The challenge

Feeding 9.7 billion people sustainably by 2050

- Climate variability is increasing uncertainty in crop performance
- Data scarcity limits adaptive decision-making
- Field-scale sensing can help explain yield variability.

How can we envision and build **future-ready, climate-smart** agricultural systems that work in real environments?

Successful innovation **isn't one-size-fits-all** – it's tailored to context.

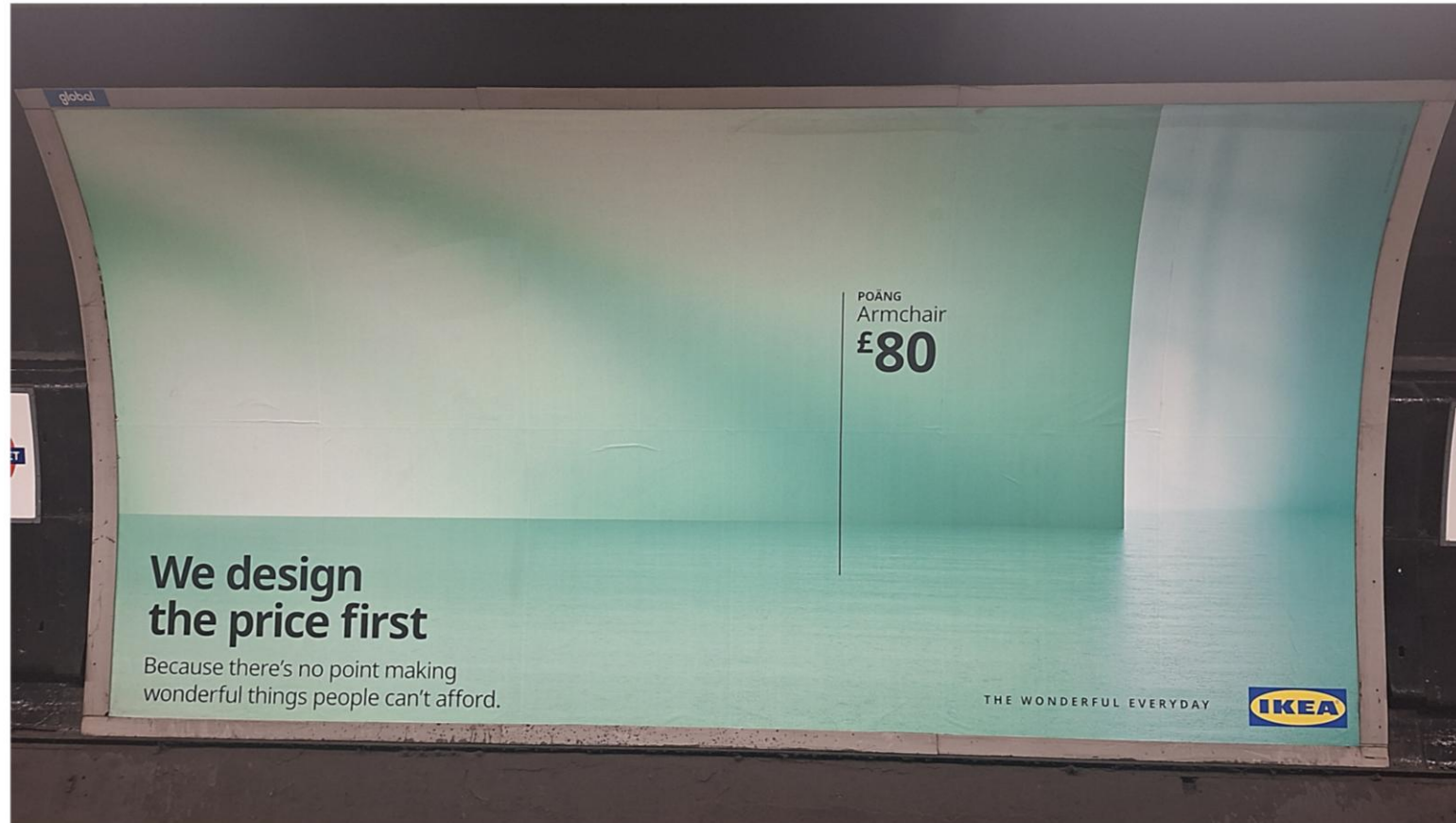

Cassava



Why Cassava?

- Staple for ~800M people
- Drought-tolerant tropical crop
- High-value starch for industry

What We are Building

- Climate-smart yield prediction & optimisation
- Low-cost rapid quality phenotyping (impedance-based)
- Early disease detection (multispectral + impedance)

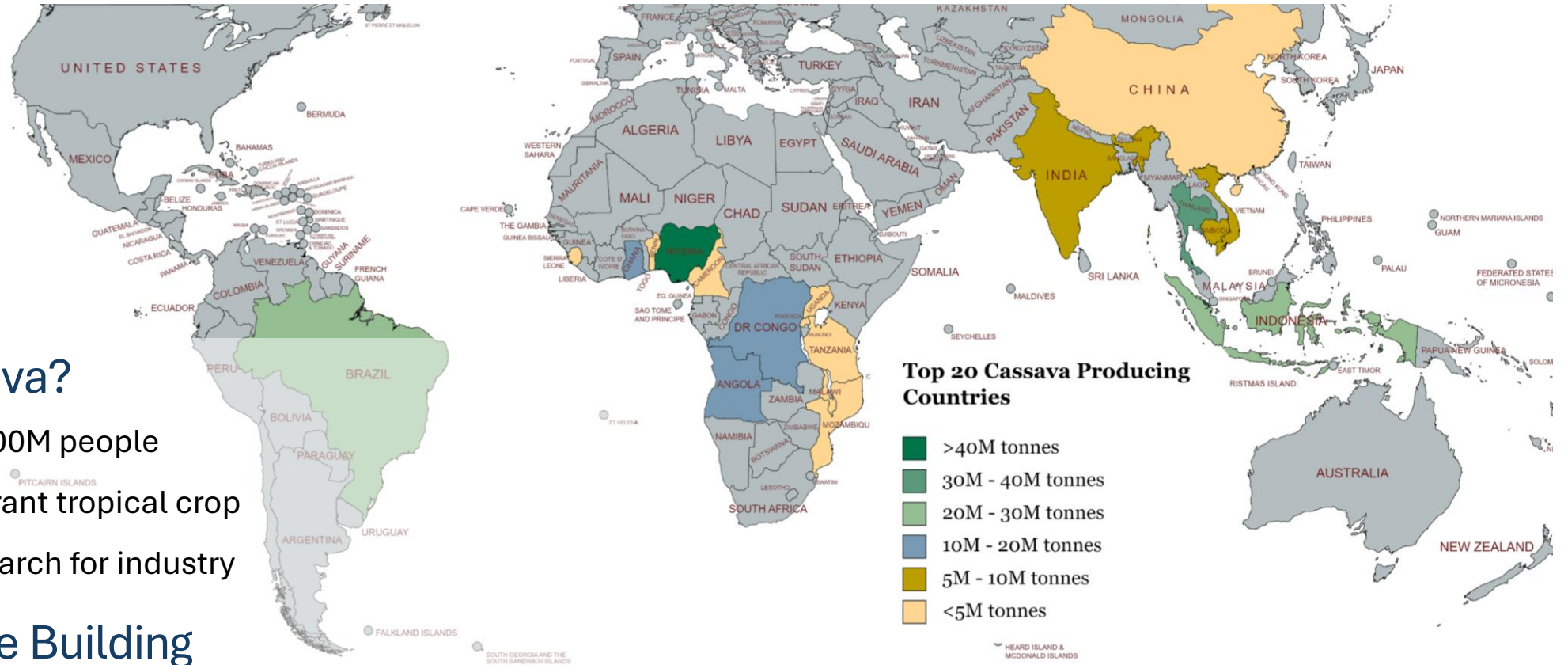

Yield Modelling: Multi-source Data Platform

12 sensing stations in Ghana & Nigeria: capturing data from soil, atmospheric and plant sensors, a mobile application for data transmission, and dashboard for analysis and visualisation.

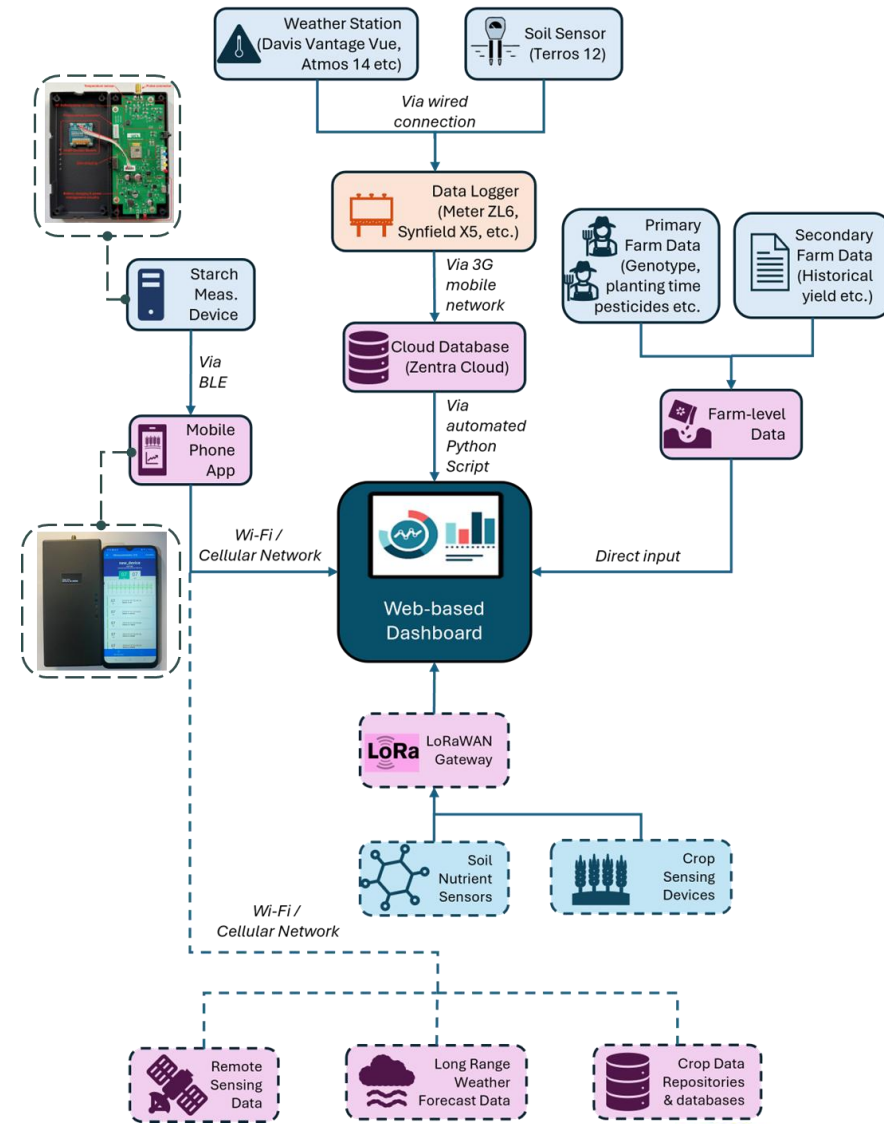
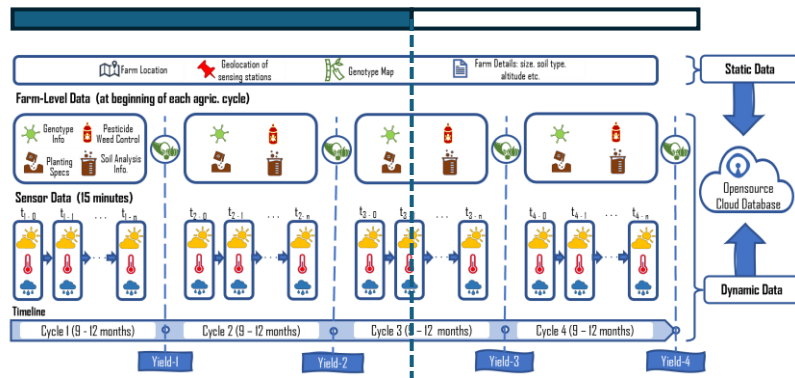

Odedeyi, T., Kolawole, O., Ugoji, C., Ayankanmi, T., Okhuoya, O., Rabbit, I., Asante, K.O.H. and Darwazeh, I., 2025, June. Multi-Source Data Integration and IoT-Based Sensing for Crop Yield Modelling and Optimisation. In *2025 IEEE International Conference on Smart Computing (SMARTCOMP)* (pp. 294-299). IEEE.

Field Design

NESTLER DEMONSTRATION FIELD

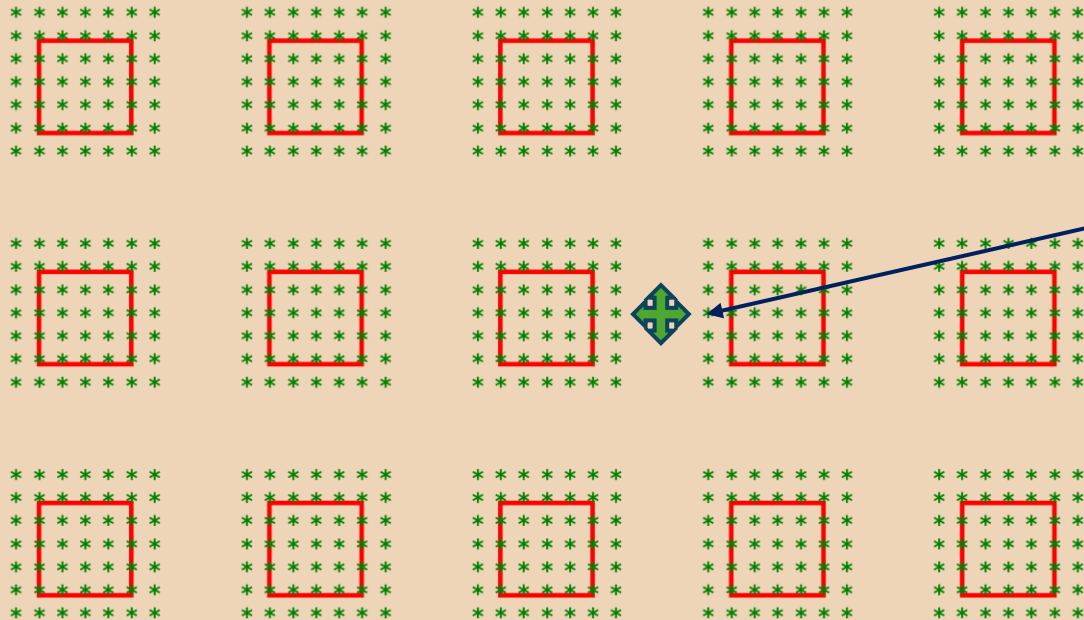

Remote Air and Soil Sensing Station

Deployment of environment sensors for yield monitoring

2023 – 2024
INSTALLATION & HARVEST AT 4
LOCATIONS:
Ibadan, Mokwa, Ubiaja, Ikenne



2024 – 2025
INSTALLATION & HARVEST AT 5
LOCATIONS:
Ibadan, Mokwa, Ubiaja, Ikenne,
Abuja



Monitoring of environment sensing station and data transmission



Harvesting of trials at maturity



Evaluation and data collection



Preparing planting materials for new establishment



Repositioning environment sensing station to new fields

This multi-season deployment enabled us to compare cassava performance under contrasting environmental conditions across agro-ecological zones.

Data Collection

- Number of roots per plot
- Root weight per plot (kg/plot)
- Shoot weight per plot (kg/plot)
- DM using specific gravity method
- Environment parameters:
 - air temperature,
 - soil moisture,
 - soil temperature,
 - saturation extract



Fresh yield across locations and agroecologies

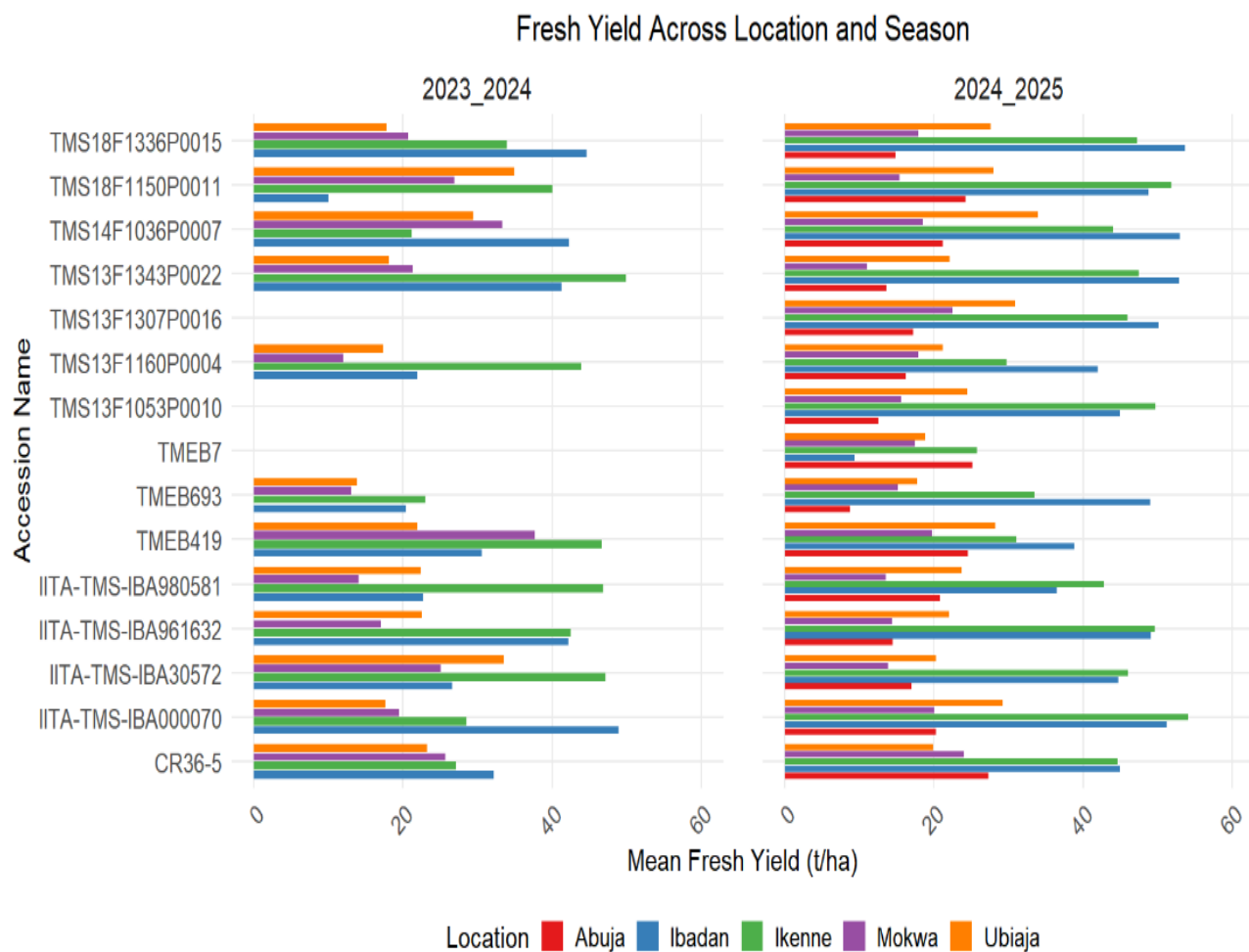

Spatial Distribution of Cassava Fresh Yield in Nigeria

NESTLER Pilot Study Locations (2023-2025 Season)

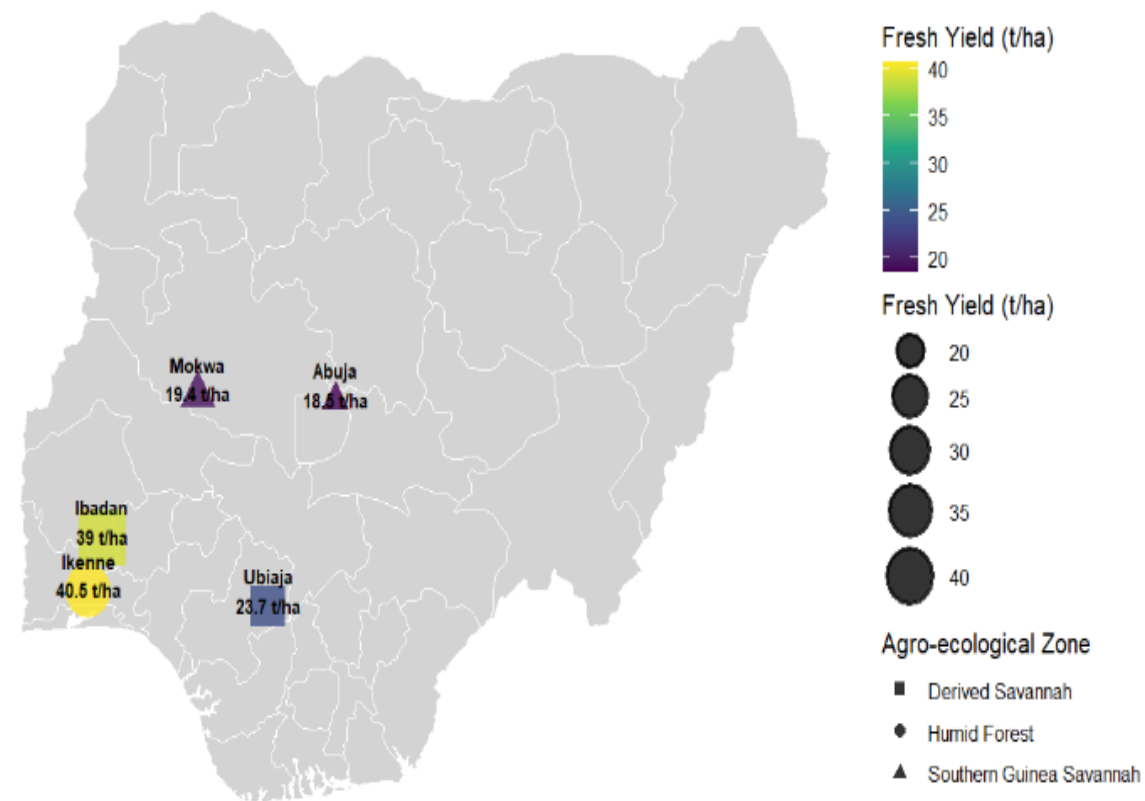

Traits performance across locations and combined seasons

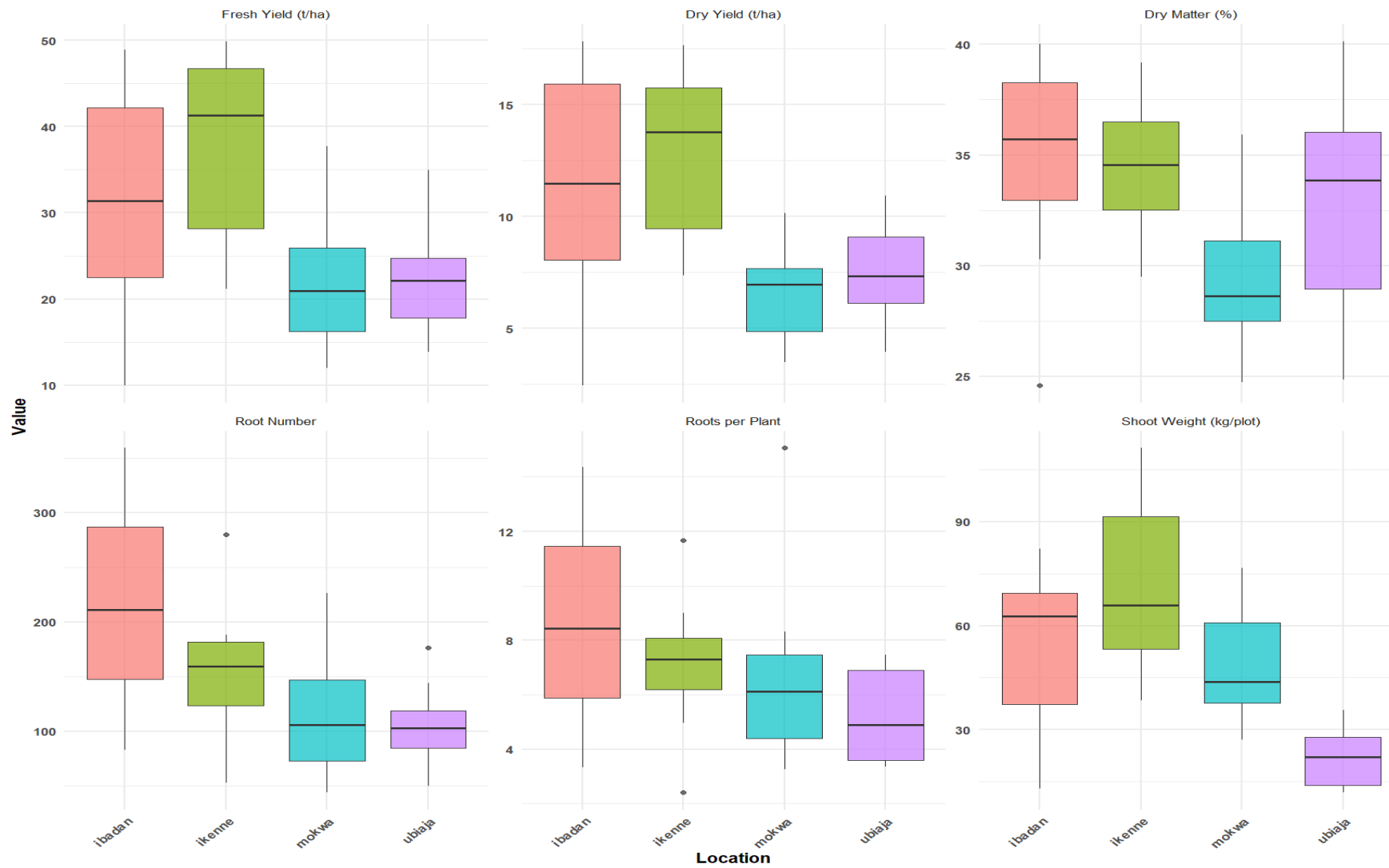

Genotypes Mean Fresh Yield By location

Heatmap: Genotypes Performance Across Locations

Ranked by overall mean yield (darker green = higher yield)

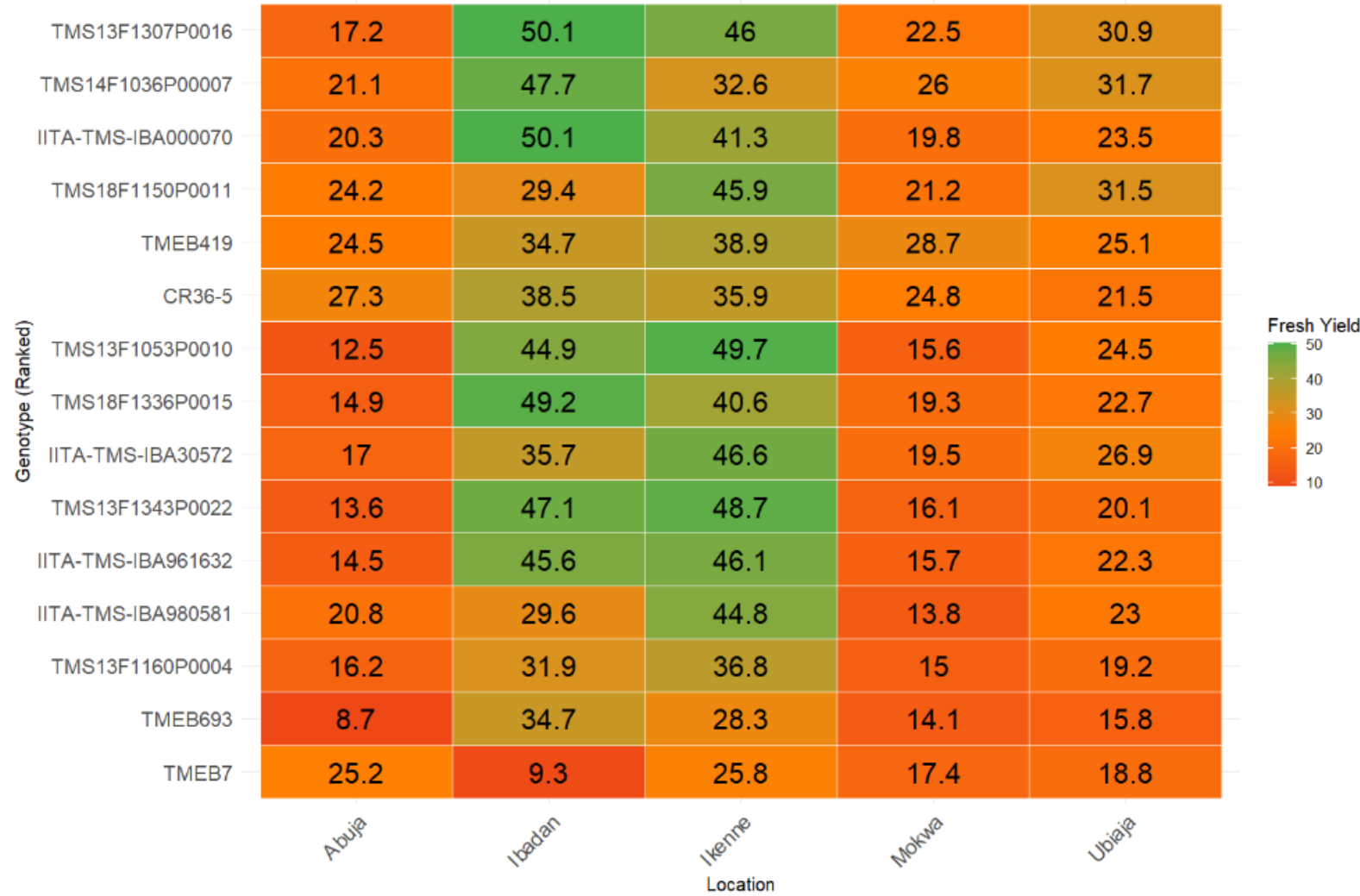

Environment Variables Distribution

Environmental Parameters Trend From Planting and Harvest Dates

Grouped by season and parameter type

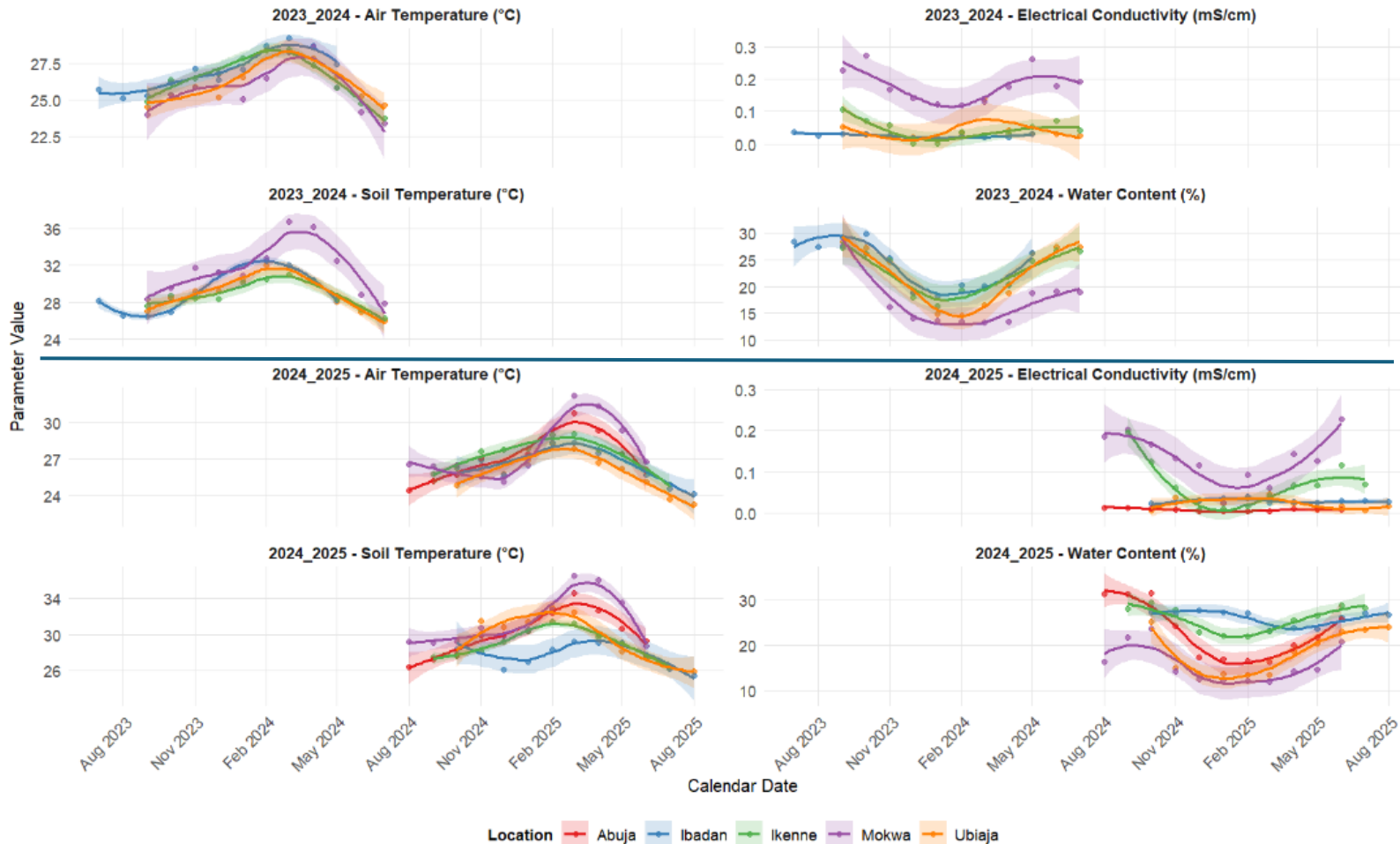

Summary of Environmental Parameters

🌡️ Temperature:

- Mokwa has the highest soil temperatures, indicating hottest soil conditions
- Ibadan shows the most stable air temperatures across seasons
- Abuja maintains moderate temperatures across both soil and air

💧 Water Content:

- Ibadan has highest water content, suggesting better soil moisture retention
- Mokwa shows lowest water content, indicating driest conditions
- Ikenne shows significant seasonal variation

⚡ Electrical Conductivity:

- Mokwa has the highest electrical conductivity (0.163 mS/cm), indicating higher salinity
- Abuja shows lowest electrical conductivity (0.00923 mS/cm), suggesting minimal salinity stress
- Ikenne shows increasing conductivity over time (0.0376 to 0.0740 mS/cm)

Linear regression: Yield vs Environment variables

A Fresh Yield vs Soil Temperature

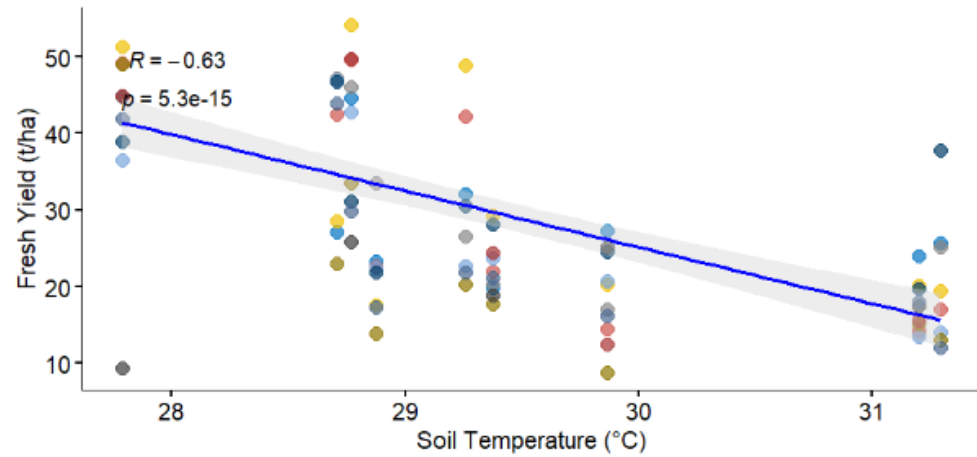

B Fresh Yield vs Water Content

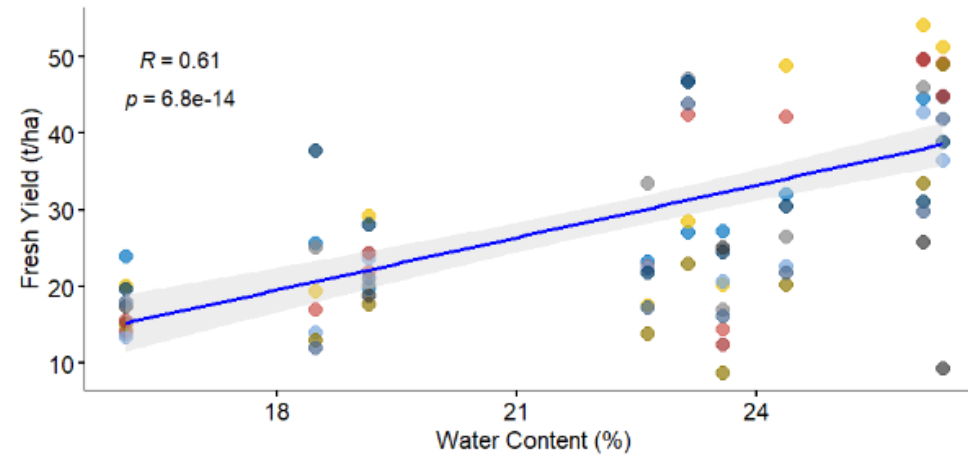

C Fresh Yield vs Electrical Conductivity

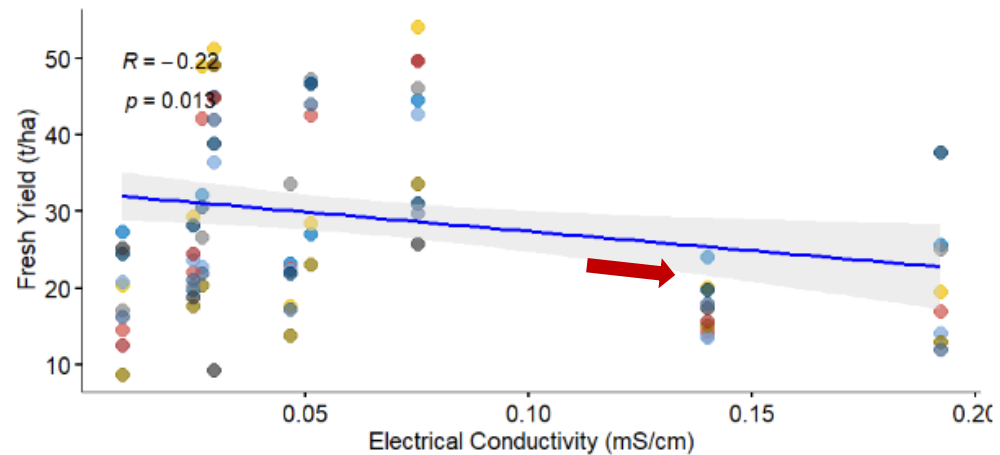

D Fresh Yield vs Air Temperature

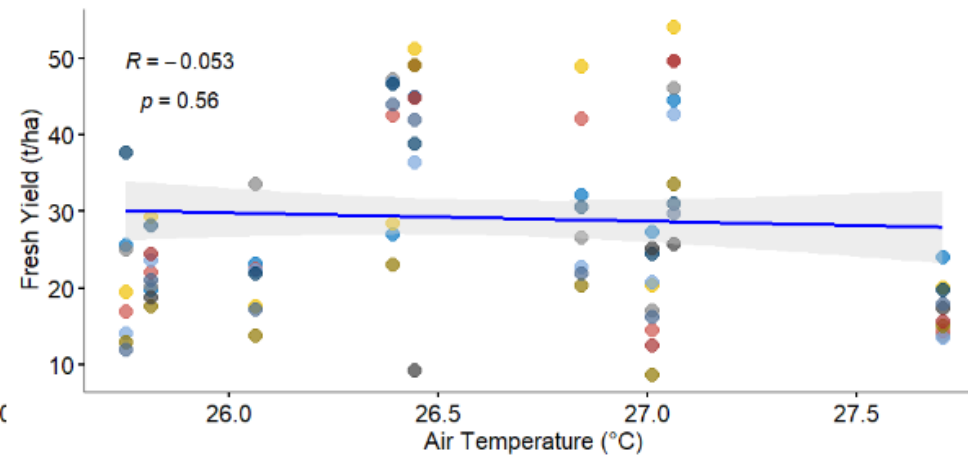

Yield modelling with environment variables

Multivariate Model: Actual vs Predicted Fresh Yield

Linear Model $R^2 = 0.864$ | RMSE = 3.64 t/ha

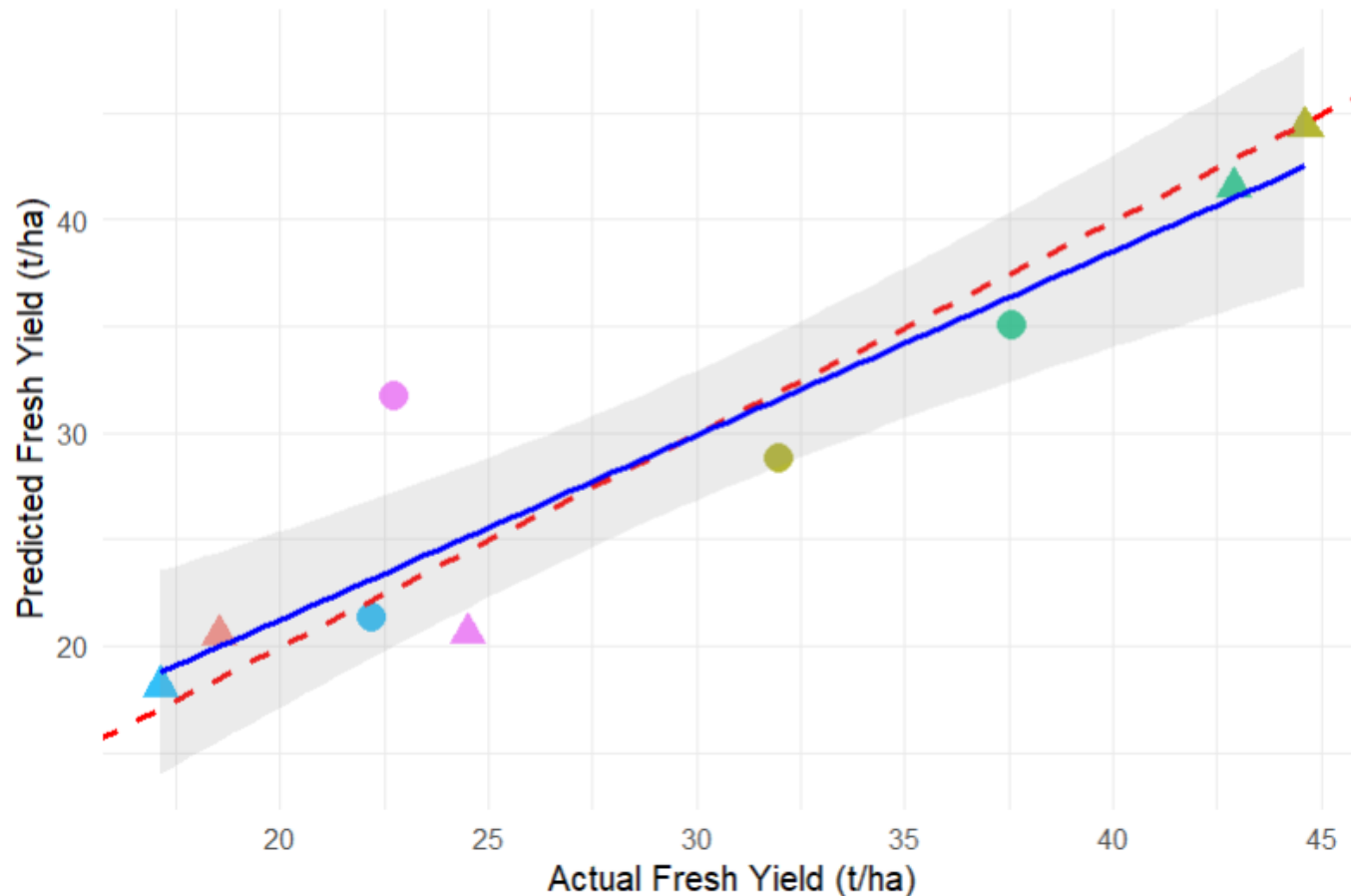

The linear model:

$\text{lm}(\text{Fresh Yield} \sim \text{soil temperature} + \text{water content} + \text{EC} + \text{air temperature})$

The model [$\text{Yield} = f(\text{soil temperature}, \text{water content}, \text{EC}, \text{air temperature})$] is testing how average monthly environmental conditions affect cassava fresh root yield across 5 locations and 2 seasons.

This model is not location-specific. It uses pooled environmental averages, so it analyses general environmental drivers of yield.

Season

- 2023_2024
- ▲ 2024_2025

Location

- Abuja
- Ibadan
- Ikenne
- Mokwa
- Ubiaja

Metric	Value
R-squared	0.864
Adjusted R-squared	0.727
RMSE	3.64
MAE	2.65
F-statistic	6.3
P-value	0.0507

Looking Forward:

Spatial Interpolation using Satellite + IoT Sensors + AI

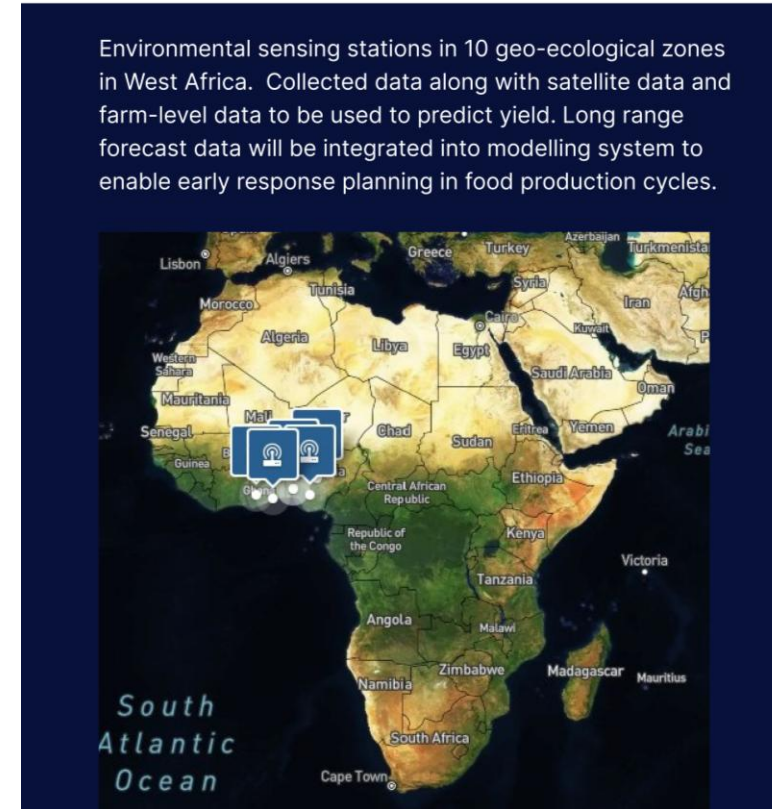

Evaluated Approaches: From simple linear regression models to random forest and generative adversarial networks

Key Takeaways

- Managing climate risk requires measuring the environments crops actually experience.
- Differences across locations reveal how crops interact with their environment and where resilience can be improved.
- Progress depends on linking field sensing, agronomy, and modelling into a coherent system.
- Combining ground sensors with satellite data and AI can transform how we observe and manage crop systems.
- Real impact comes not from sensors alone, but from solutions designed for the realities of farming environments.





Thank you for listening.



System Architecture for Plant Physiological Monitoring via Stem Impedance Measurement

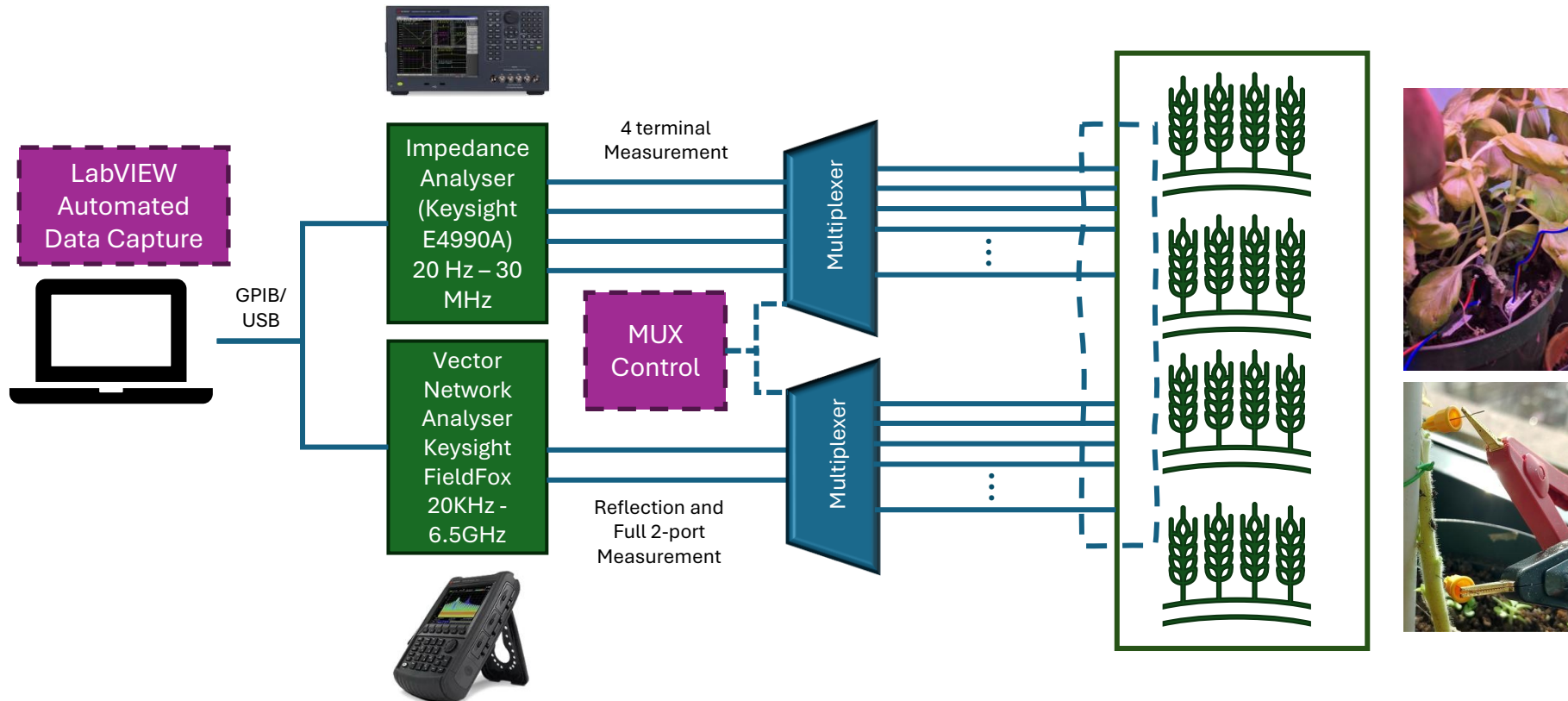

- Stem impedance measurement used to monitor internal plant physiological conditions.
- Impedance variations correlate with plant water status, nutrient flow, and physiological stress.

Traits performance across locations and combined seasons

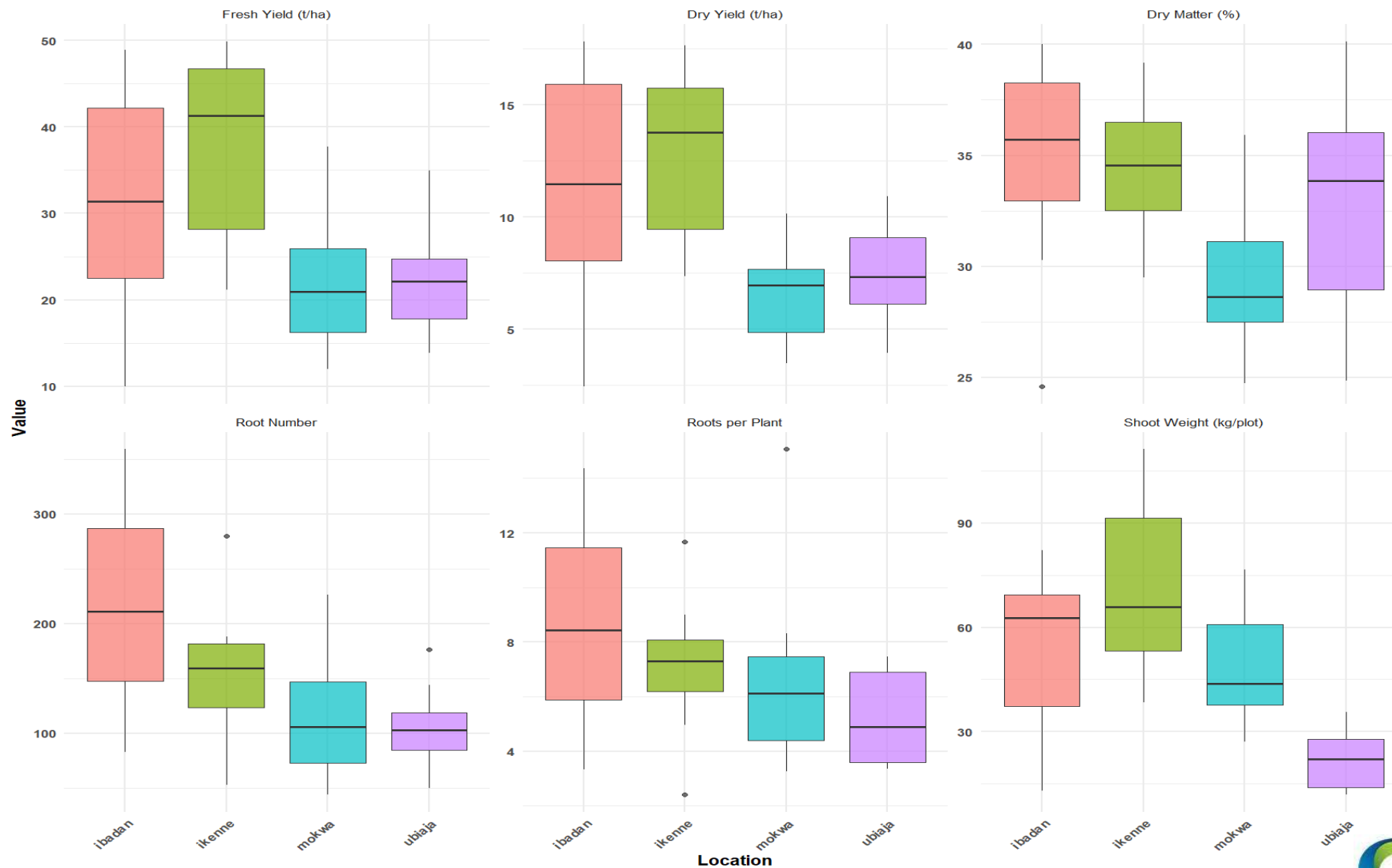

Genotypes Mean Fresh Yield By location

Heatmap: Genotypes Performance Across Locations

Ranked by overall mean yield (darker green = higher yield)

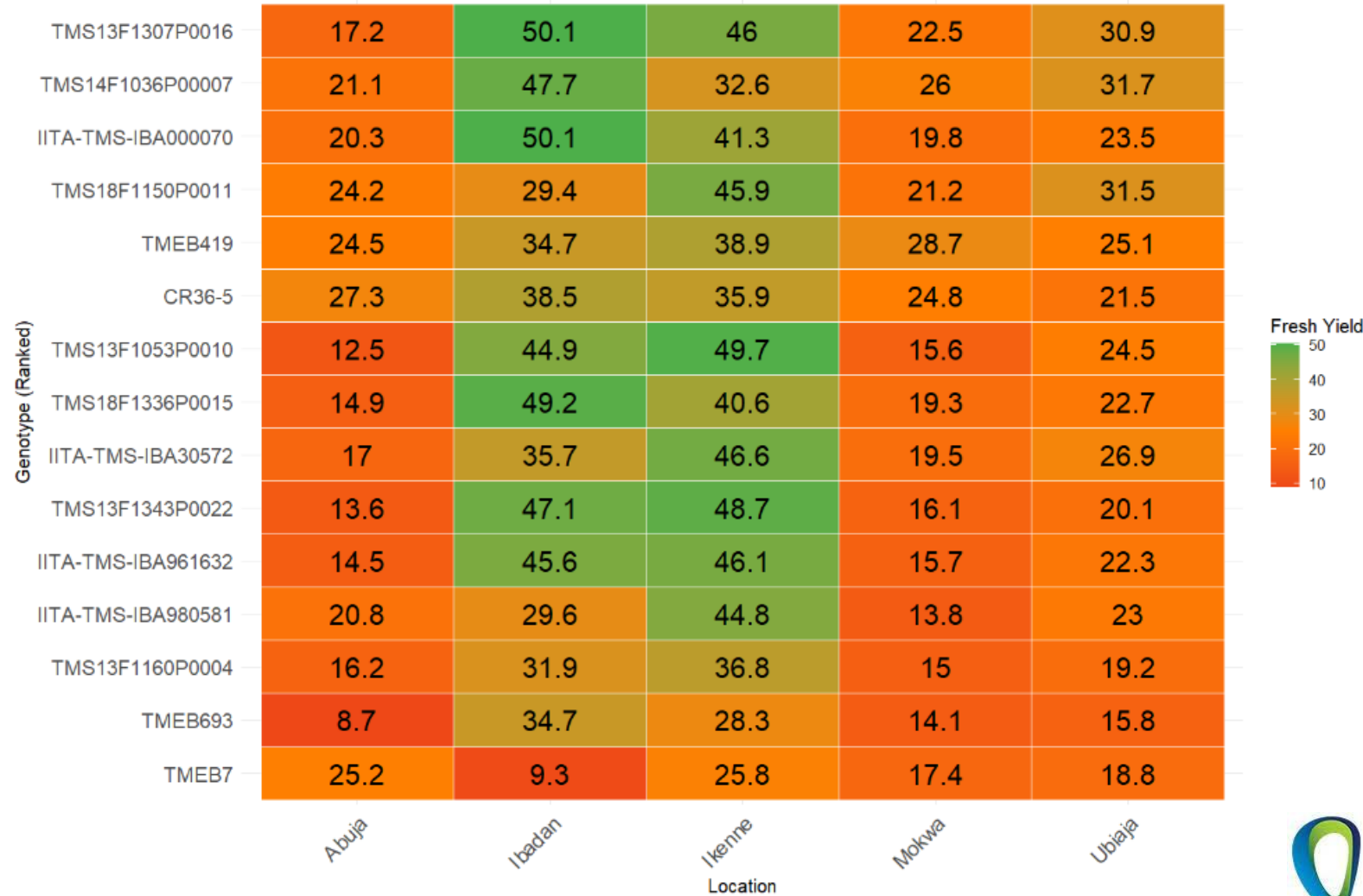

Correlation

Yield vs Environmental Variables Correlation

Significance: *p<0.05, **p<0.01, ***p<0.001, ns=not significant

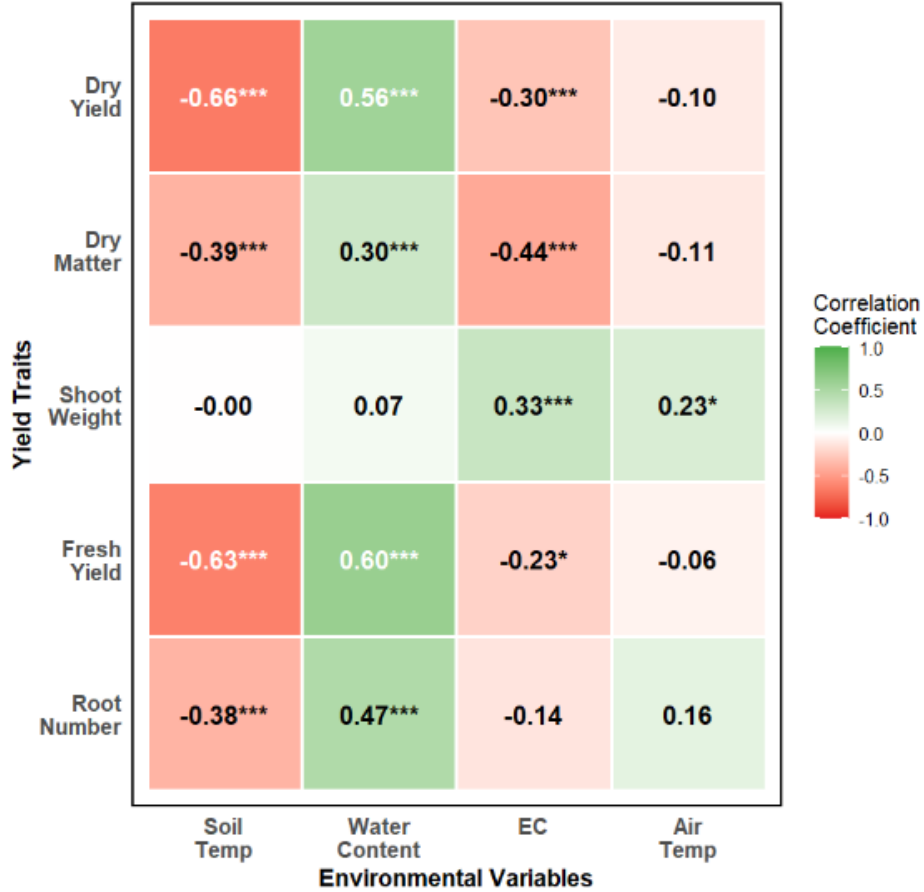

Correlation Among Yield Traits

Significance: *p<0.05, **p<0.01, ***p<0.001

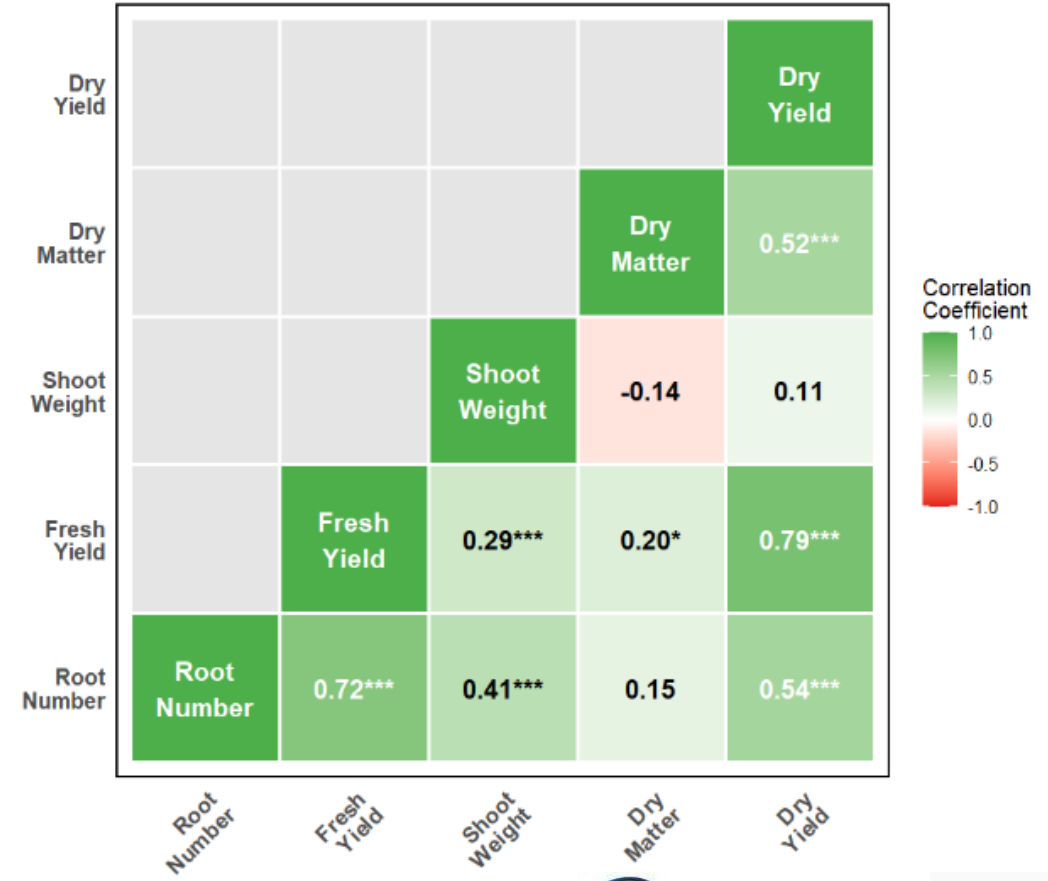

Correlation

Correlation Heatmap: Yield and Environment Variables
All pairwise linear relationships



Correlation (r)  -1.0 0.50 0.0 0.5 1.0

Environment parameters phases

Environment parameters averaged into 4 windows before harvest (Mean \pm SD (Min–Max))

Parameter	Growth Stage	2023–2024	2024–2025
Soil Temperature (°C)	E1 (1–3 months)	28.37 \pm 1.45 (26.44–31.74)	28.51 \pm 1.57 (26.16–31.5)
Soil Temperature (°C)	E2 (4–6 months)	30.22 \pm 1.66 (26.99–32.79)	30.1 \pm 1.64 (26.99–32.93)
Soil Temperature (°C)	E3 (7–9 months)	31.81 \pm 2.64 (28.04–36.78)	30.95 \pm 2.92 (27.39–36.5)
Soil Temperature (°C)	E4 (10–12 months)	27.73 \pm 1.45 (25.99–30.42)	28.44 \pm 2.8 (25.46–33.54)
Water Content (%)	E1 (1–3 months)	26.16 \pm 3.45 (16.13–29.26)	24.71 \pm 5.89 (13.72–31.47)
Water Content (%)	E2 (4–6 months)	18.09 \pm 5.05 (13.34–29.92)	19.85 \pm 6.38 (12.23–31.48)
Water Content (%)	E3 (7–9 months)	19.18 \pm 3.85 (13.21–26.28)	19.93 \pm 5.07 (11.87–26.48)
Water Content (%)	E4 (10–12 months)	24.13 \pm 3.92 (18.91–27.51)	23.74 \pm 4.26 (14.65–28.81)
Electrical Conductivity (mS/cm)	E1 (1–3 months)	0.09 \pm 0.09 (0.03–0.27)	0.08 \pm 0.08 (0–0.1)
Electrical Conductivity (mS/cm)	E2 (4–6 months)	0.05 \pm 0.05 (0–0.14)	0.04 \pm 0.04 (0.01–0.13)
Electrical Conductivity (mS/cm)	E3 (7–9 months)	0.08 \pm 0.08 (0.02–0.26)	0.04 \pm 0.04 (0–0.14)
Electrical Conductivity (mS/cm)	E4 (10–12 months)	0.07 \pm 0.07 (0.02–0.19)	0.06 \pm 0.07 (0.01–0.23)
Air Temperature (°C)	E1 (1–3 months)	25.4 \pm 0.72 (24–26.47)	26.01 \pm 0.84 (24.47–27.66)
Air Temperature (°C)	E2 (4–6 months)	26.76 \pm 1.07 (25.07–28.39)	27.22 \pm 1.14 (25.15–28.97)
Air Temperature (°C)	E3 (7–9 months)	27.6 \pm 1.13 (25.83–29.23)	28.25 \pm 2.06 (25.15–32.22)
Air Temperature (°C)	E4 (10–12 months)	25.23 \pm 1.86 (23.35–28.26)	25.98 \pm 2.1 (23.29–29.38)

PCA

PCA Biplot: Accessions and Yield Traits by Location

Arrows show yield trait contributions | Points colored by location

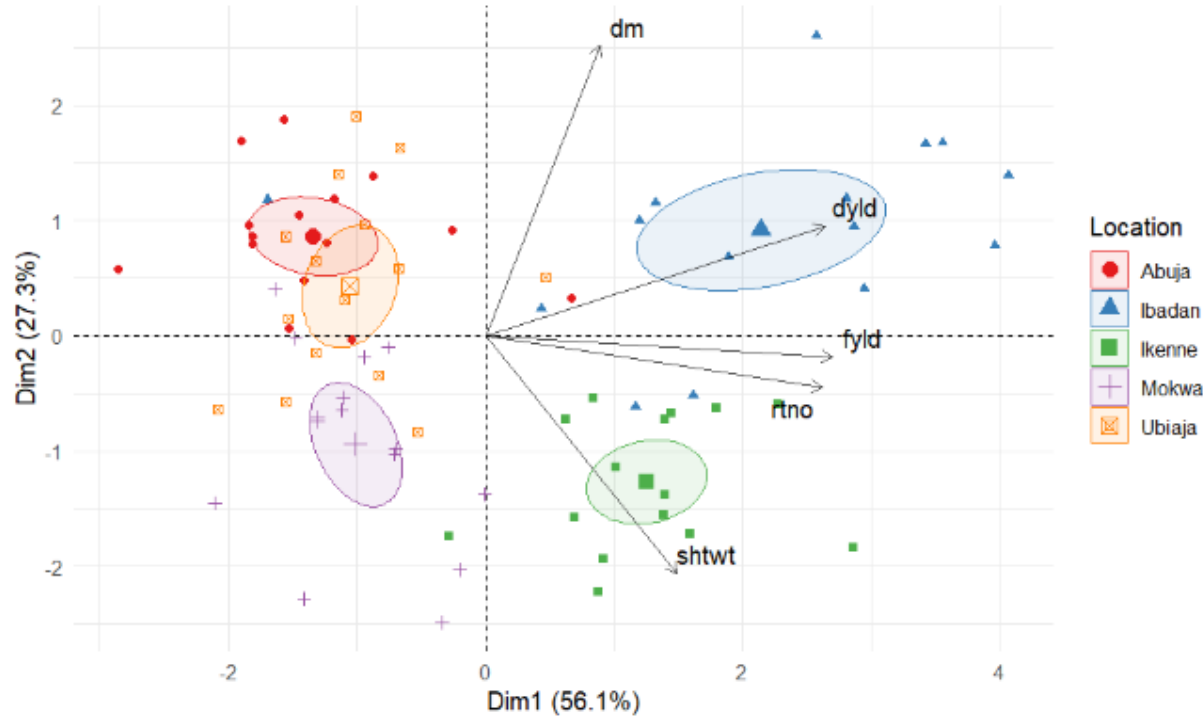

Biplot: Environmental Phases and Yield Traits

Arrows show variable loadings

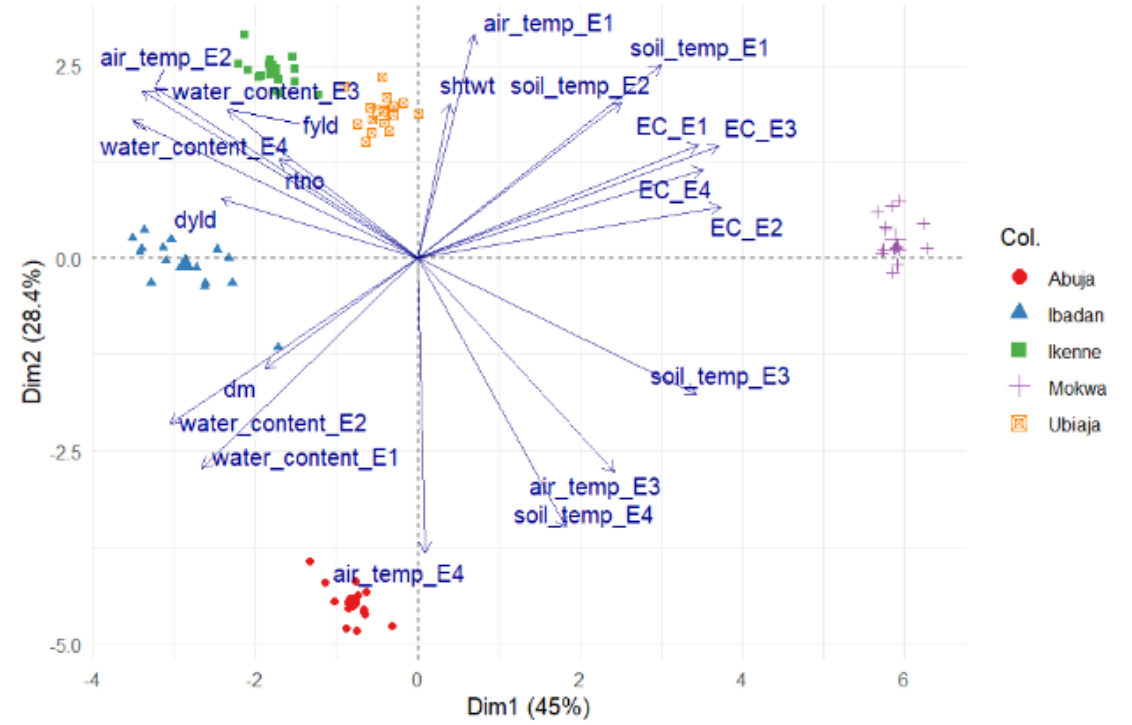

Soil Physical and Chemical Properties

Season	Location	pH	P (ppm)	Nitrogen%	O.carbon%	% Sand	% Clay	% silt
2024/2025	Ubiaja	4.92	2.518	0.066	0.125	82	12	6
2024/2025	Ikenne	4.21	15.920	0.116	0.116	78	16	6
2024/2025	Abuja	5.45	5.597	0.030	0.027	84	12	4
2024/2025	Mokwa	5.24	3.315	0.052	0.094	82	12	6
2024/2025	Ibadan	6.33	16.82	0.10	0.25	76.67	16	7.33

Correlations Between Soil Parameters and Yield Traits (2024/2025)

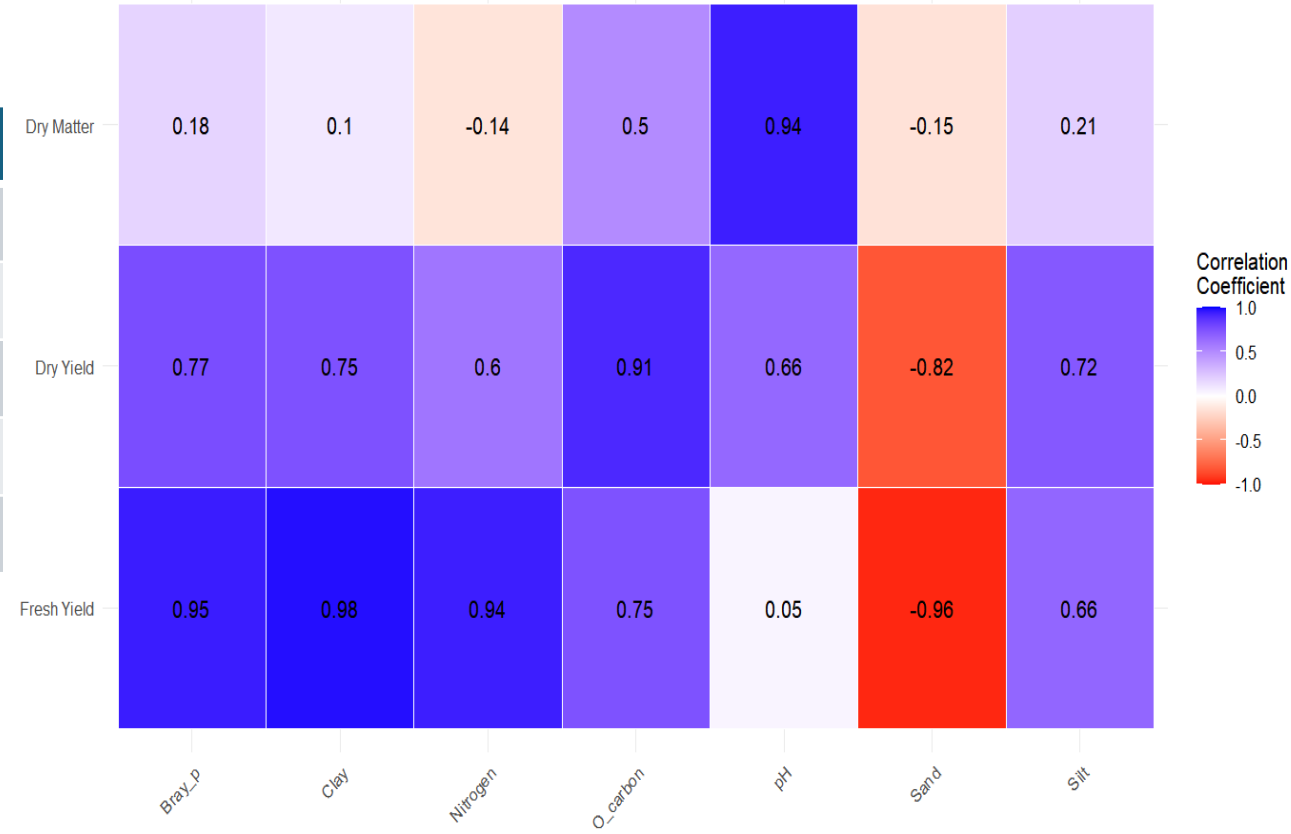

Model summary and performance

Term	Estimate	Std. Error	t value	P-value	Significance
Intercept	229.1427	125.7157	1.823	0.1424	n.s
soil_temp	-9.7116	3.9047	-2.487	0.0677	• (marginal)
water_content	0.8954	1.0637	0.842	0.4473	n.s
EC	120.5977	48.8050	2.471	0.0689	• (marginal)
air_temp	2.1920	3.2598	0.672	0.5382	n.s

Location	Season	Actual Yield	Predicted Yield	Residual
Abuja	2024_2025	18.54	20.50	-1.96
Ibadan	2023_2024	31.96	28.87	3.09
Ibadan	2024_2025	44.62	44.36	0.25
Ikenne	2023_2024	37.57	35.11	2.46
Ikenne	2024_2025	42.91	41.50	1.41
Mokwa	2023_2024	22.18	21.38	0.80
Mokwa	2024_2025	17.13	18.12	-0.99
Ubiaja	2023_2024	22.73	31.72	-8.99
Ubiaja	2024_2025	24.51	20.59	3.92